

Driveshaft — 4.6L and 5.4L

Material

Item	Specification
Threadlock and Sealer TA-25	WSK-M2G351-A5

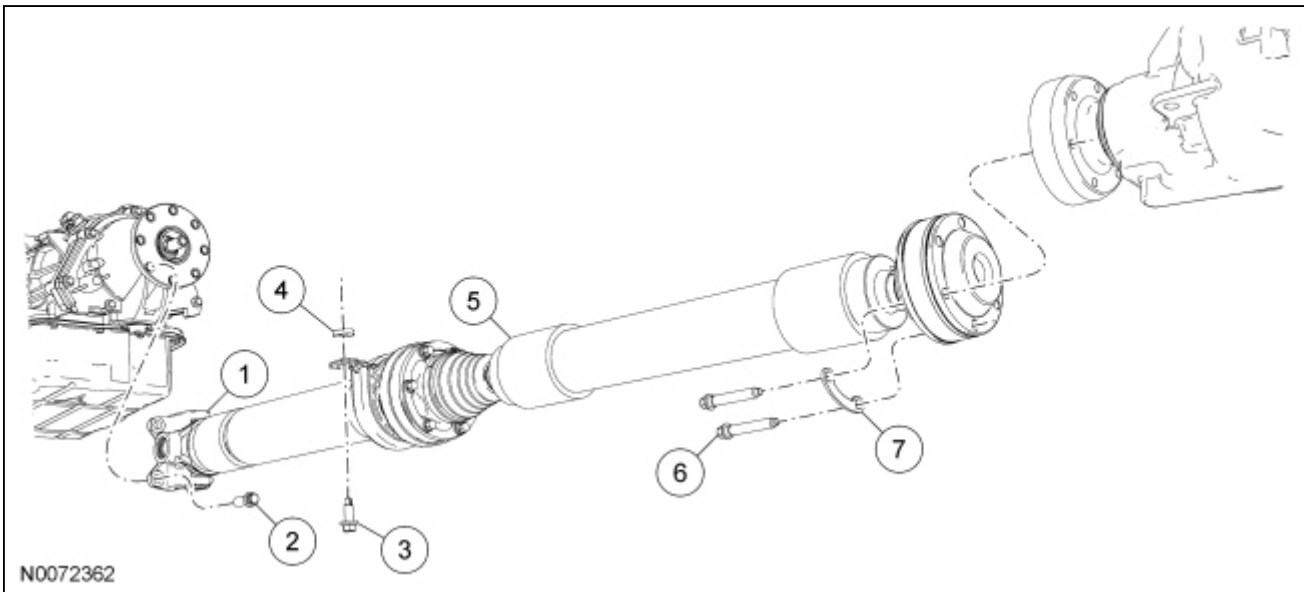

Item	Part Number	Description
1	—	Driveshaft flange (part of 4K145)
2	N800594	Driveshaft flange bolt (4 required)
3	N506434	Center bearing bolt (2 required)
4	W710432	Spacer (2 required)
5	4K145	Driveshaft assembly
6	W708259	Driveshaft CV joint bolt (6 required)
7	4682	Driveshaft joint washer (3 required)

Removal and Installation

1. With the vehicle in NEUTRAL, position it on a hoist. For additional information, refer to [Section 100-02](#).
2. Index-mark the driveshaft at both ends to maintain alignment during installation.

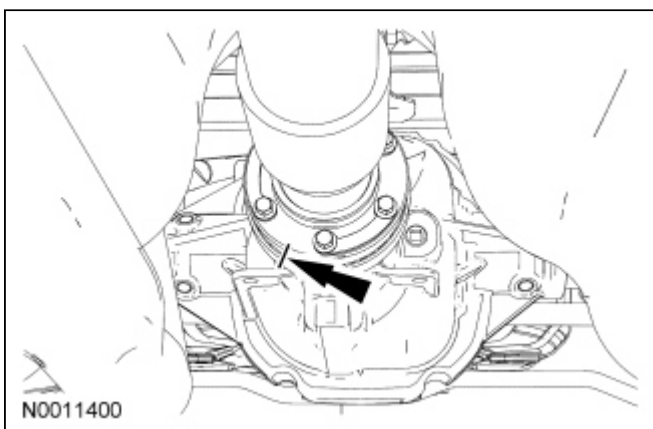
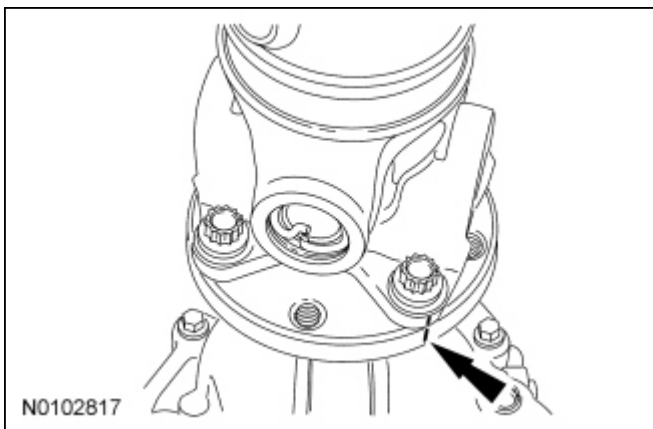

3. Remove and discard the 6 driveshaft CV joint bolts and CV joint washers, then disconnect the CV joint from the pinion flange.
 - To install, tighten the new bolts in a star pattern to 55 Nm (41 lb-ft).

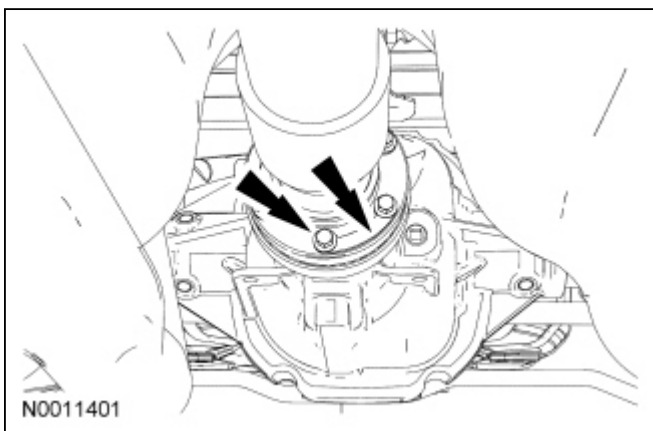

4. **NOTE:** If new driveshaft flange bolts are not available, coat the threads of the original driveshaft flange bolts with threadlock and sealer.

Remove and discard the 4 driveshaft flange bolts.

- To install, tighten the new bolts in a cross pattern to 103 Nm (76 lb-ft).

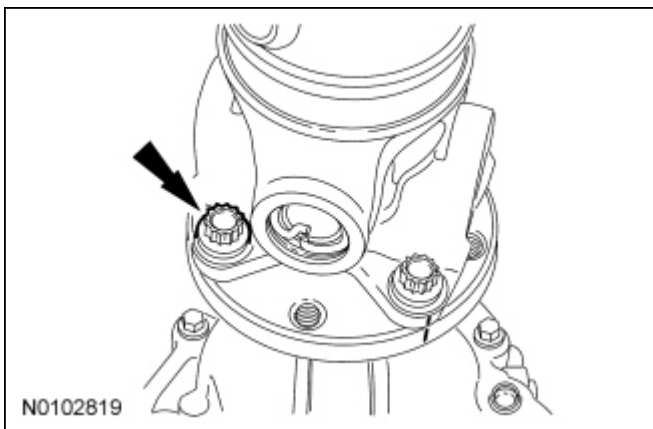

5. **NOTE:** The driveshaft flanges fit tightly on the transmission flange pilot. Never hammer on the driveshaft or any of its components to disconnect the driveshaft flange from the transmission flange pilot. Pry only in the area shown, with a suitable tool, to disconnect the driveshaft flange from the transmission flange pilot.

Using a suitable tool as shown, disconnect the driveshaft flange from the transmission flange pilot.

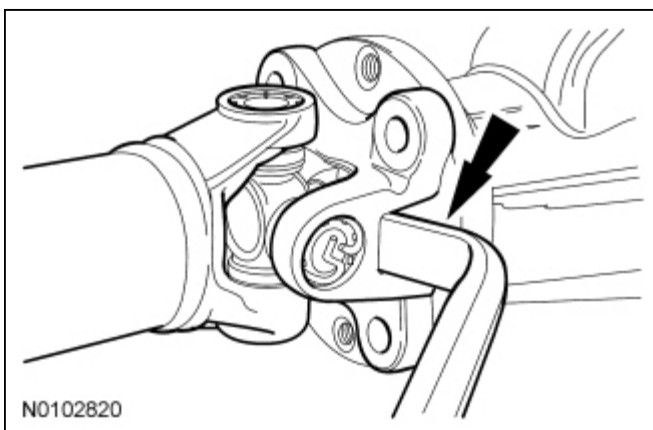

6. **NOTE:** The center bearing spacers must be installed between the body and the center bearing bracket.

Remove and discard the 2 center bearing bolts and spacers, then remove the driveshaft.

- Install the new center bearing bolts finger-tight until after the front and rear flanges are tightened to specifications.
 - To install, tighten the bolts to 48 Nm (35 lb-ft).

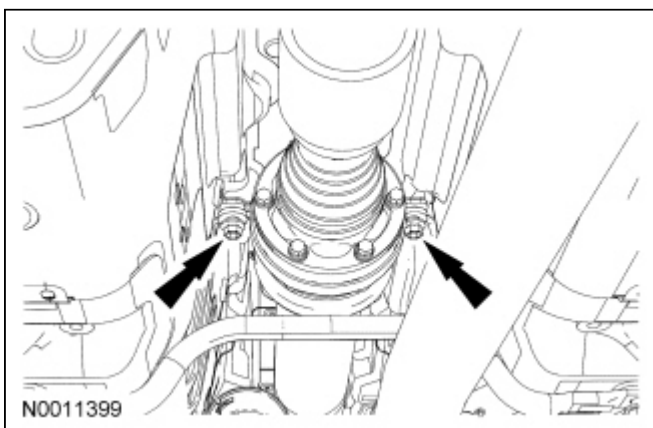

7. **NOTE:** The driveshaft flanges fit tightly on the transmission output flange pilot. To make sure that the driveshaft flange seats squarely on the transmission output flange, tighten the driveshaft flange bolts evenly in

a cross pattern.

NOTE: If new driveshaft flange bolts, center bearing bolts and spacers are not available, coat the threads of the original driveshaft flange bolts and center bearing bolts with threadlock and sealer and reuse the original spacers.

NOTE: Tighten the CV joint bolts evenly in a star pattern.

To install, reverse the removal procedure.
